



Bowl Cutters

Models FP-CN-0006, 0009, 0012

Items 23545, 23546, 47507

Instruction Manual



Revised - 07/27/2022



Toll Free: 1-800-465-0234
Fax: 905-607-0234
Email: service@omcan.com
www.omcan.com

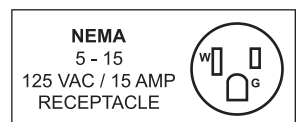

Table of Contents

Model FP-CN-0006 / Model FP-CN-0009 / Model FP-CN-0012

Section	Page
General Information -----	3 - 4
Safety and Warranty -----	4 - 5
Technical Specifications -----	6
Installation -----	6
Operation -----	7
Maintenance -----	7 - 8
Parts Breakdown -----	9 - 12
Electrical Schematics -----	13
Notes -----	14
Warranty Registration -----	15



General Information

Omcan Manufacturing and Distributing Company Inc., Food Machinery of America, Inc. dba Omcan and Omcan Inc. are not responsible for any harm or injury caused due to any person's improper or negligent use of this equipment. The product shall only be operated by someone over the age of 18, of sound mind, and not under the influence of any drugs or alcohol, who has been trained in the correct operation of this machine, and is wearing authorized, proper safety clothing. Any modification to the machine voids any warranty, and may cause harm to individuals using the machine or in the vicinity of the machine while in operation.

CHECK PACKAGE UPON ARRIVAL

Upon receipt of an Omcan shipment please inspect for external damage. If no damage is evident on the external packaging, open carton to ensure all ordered items are within the box, and there is no concealed damage to the machine. If the package has suffered rough handling, bumps or damage (visible or concealed), please note it on the bill of lading before accepting the delivery and contact Omcan within 24 hours, so we may initiate a claim with the carrier. A detailed report on the extent of the damage caused to the machine must be filled out within three days, from the delivery date shown in the shipping documents. Omcan has no recourse for damaged products that were shipped collect or third party.

Before operating any equipment, always read and familiarize yourself with all operation and safety instructions.

Omcan would like to thank you for purchasing this machine. It's of the utmost importance to save these instructions for future reference. Also save the original box and packaging for shipping the equipment if servicing or returning of the machine is required.

Omcan Fabrication et distribution Compañie Limité et Food Machinery d'Amérique, dba Omcan et Omcan Inc. ne sont pas responsables de tout dommage ou blessure causé du fait que toute personne ait utilisé cet équipement de façon irrégulière. Le produit ne doit être exploité que par quelqu'un de plus de 18 ans, saine d'esprit, et pas sous l'influence d'une drogue ou d'alcool, qui a été formé pour utiliser cette machine correctement, et est vêtu de vêtements de sécurité approprié. Toute modification de la machine annule toute garantie, et peut causer un préjudice à des personnes utilisant la machine ou des personnes à proximité de la machine pendant son fonctionnement.

VÉRIFIEZ LE COLIS DÈS RÉCEPTION

Dès réception d'une expédition d'Omcan veuillez inspecter pour dommages externes. Si aucun dommage n'est visible sur l'emballage externe, ouvrez le carton afin de s'assurer que tous les éléments commandés sont dans la boîte, et il n'y a aucun dommage dissimulé à la machine. Si le colis n'a subi aucune mauvaises manipulations, de bosses ou de dommages (visible ou cachée), notez-le sur le bond de livraison avant d'accepter la livraison et contactez Omcan dans les 24 heures qui suivent, pour que nous puissions engager une réclamation auprès du transporteur. Un rapport détaillé sur l'étendue des dommages causés à la machine doit être rempli dans un délai de trois jours, à compter de la date de livraison indiquée dans les documents d'expédition. Omcan n'a aucun droit de recours pour les produits endommagés qui ont été expédiés ou cueilli par un tiers transporteur.

General Information

Avant d'utiliser n'importe quel équipement, toujours lire et vous familiariser avec toutes les opérations et les consignes de sécurité.

Omcan voudrais vous remercier d'avoir choisi cette machine. Il est primordial de conserver ces instructions pour une référence ultérieure. Également conservez la boîte originale et l'emballage pour l'expédition de l'équipement si l'entretien ou le retour de la machine est nécessaire.

Omcan Empresa De Fabricacion Y Distribucion Inc. Y Maquinaria De Alimentos De America, Inc. dba Omcan y Omcan Inc. no son responsables de ningun daño o perjuicio causado por cualquier persona inadecuada o el uso descuidado de este equipo. El producto solo podra ser operado por una persona mayor de 18 años, en su sano juicio y no bajo alguna influencia de droga o alcohol, y que este ha sido entrenado en el correcto funcionamiento de esta máquina, y ésta usando ropa apropiada y autorizada. Cualquier modificación a la máquina anula la garantía y puede causar daños a las personas usando la máquina mientras esta en el funcionamiento.

REVISE EL PAQUETE A SU LLEGADA

Tras la recepcion de un envio Omcan favor inspeccionar daños externos. Si no hay daños evidentes en el empaque exterior, Habra el carton para asegurarse que todos los articulos solicitados estén dentro de la caja y no encuentre daños ocultos en la máquina. Si el paquete ha sufrido un manejo de poco cuidado, golpes o daños (visible o oculto) por favor anote en la factura antes de aceptar la entrega y contacte Omcan dentro de las 24 horas, de modo que podamos iniciar una reclamación con la compañía. Un informe detallado sobre los daños causados a la máquina debe ser llenado en el plazo de tres días, desde la fecha de entrega que se muestra en los documentos de envío. Omcan no tiene ningun recurso por productos dañados que se enviaron a recoger por terceros.

Antes de utilizar cualquier equipo, siempre lea y familiarizarse con todas las instrucciones de funcionamiento y seguridad.

Omcan le gustaría darle las gracias por la compra de esta máquina. Es de la mayor importancia para salvar estas instrucciones para futuras consultas. Además, guarda la caja original y el embalaje para el envío del equipo si servicio técnico o devolución de la máquina que se requiere.

Safety and Warranty

- This machine should only be operated by trained users. Before operating, users should know about the protection measures.
- Please turn off and unplug the machine before cleaning and maintenance.
- When you remove the protective measures in order to clean and maintain the machine, you should always proceed with caution.
- Damaged power cables may cause electric shock and should be replaced before any further operation.
- Please contact Omcan if you need to adjust or maintain the machine.



Safety and Warranty

- This machine must not be used to process bones, frozen meat or fish and non-food products.
- When the machine is in operation, do not put your hand into the bowl.

SAFETY DEVICES

- The cover plays an important role in protecting the user. The cover can only be moved away when the arm is unlocked.
- When the arm is unlocked or if the cover is not in place, the machine stops working.
- If the power cuts off unexpectedly, the machine must be restarted.
- Use the utmost care when using this machine.

NOTE: THESE BOWL CUTTERS ARE NOT IDEAL FOR MAKING LARGE BATCHES OF HUMMUS.

RESIDENTIAL USERS: Vendor assumes no liability for parts or labor coverage for component failure or other damages resulting from installation in non-commercial or residential applications. The right is reserved to deny shipment for residential usage; if this occurs, you will be notified as soon as possible.

1 YEAR PARTS AND LABOUR WARRANTY

Within the warranty period, contact Omcan Inc. at 1-800-465-0234 to schedule an Omcan authorized service technician to repair the equipment locally.

Unauthorized maintenance will void the warranty. Warranty covers electrical and part failures, not improper use.

Please see <https://omcan.com/disclaimer> for complete info.

WARNING:

The packaging components (cardboard, polyethylene, and others) are classified as normal solid urban waste and can therefore be disposed of without difficulty.

In any case, for suitable recycling, we suggest disposing of the products separately (differentiated waste) according to the current norms.

DO NOT DISCARD ANY PACKAGING MATERIALS IN THE ENVIRONMENT!

Technical Specifications

FEATURES OF THE MACHINE

This machine is made with 304 stainless steel, it ensures that any components that touch food are clean. The knives are made with 4Cr13 stainless steel, which makes the knives more sharp and efficient. There is also a stainless steel bottom which can withstand heated product.

COMPONENTS

1. Container.
2. Cover.
3. Arm Lock.
4. Main Body.
5. Power Cable.
6. Feet.
7. Control Panel.
8. Knob for Controlling Speed.

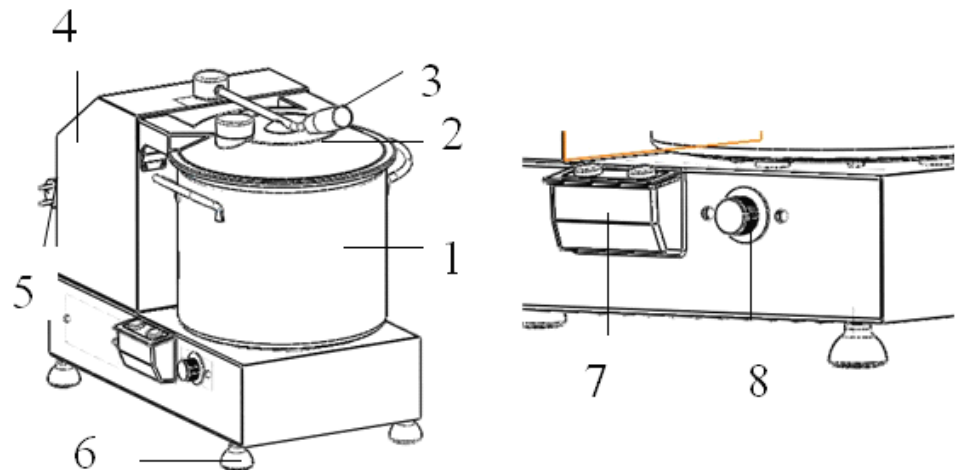

TECHNICAL DATA

Model	FP-CN-0006	FP-CN-0009	FP-CN-0012
Power	1800 W		2000 W
Electrical	110V / 60Hz / 1		
Speed	986 - 2470 RPM		
Food Bowl Dimensions (Dia. x H)	10" x 6.1" 253 x 155mm	10" x 8.1" 253 x 205mm	10" x 9.8" 253 x 250mm
Capacity of Food Bowl	6 L / 6.3 QT	9 L / 9.5 QT	12 L / 12.7 QT
Dimensions	12.5" x 20.6" x 15.5" 317 x 523 x 394mm	12.5" x 20.6" x 17.5" 317 x 523 x 444mm	12.5" x 20.6" x 19.3" 317 x 523 x 489mm
Weight	41.7 lbs. / 18.9 kgs.	45 lbs. / 20.4 kgs.	48 lbs. / 21.8 kgs.
Packaging Dimensions	14.8" x 22.2" x 17.3" 377 x 565 x 440mm	15.5" x 22.4" x 18.5" 393 x 568 x 470mm	15.2" x 22.4" x 20.9" 385 x 570 x 532mm
Packaging Weight	45.3 lbs. / 20.6 kgs.	48.6 lbs. / 22.1 kgs.	51.9 lbs. / 23.6 kgs.
Item Number	23545	23546	47507

Installation

The machine should be placed on a dry, level table which must be large enough to support the machine. When it is installed, the room temperature should be set between +5°C and +35°C.

CONTROLLER

1. Set the rotating speed via the knob for controlling speed.
2. Start the machine by pressing the On/Off switch to “I”.
3. Stop the machine by pressing the On/Off switch to “O”

FOOD FEEDING

Attention: Food is to be fed only when the machine is stopped. The knob for controlling speed must be set at the “o” position.

PROCEDURES

1. Turn the loading arm in the counterclockwise direction to remove the cover.
2. Pay attention to the two blades while feeding food into the container; Food should be cut into small blocks before feeding.

Warning: the food in the container is not allowed to exceed more than half of the total volume of the bowl.

3. In case of accidents, the user should pay attention on his own position when using the machine. The user’s body should be vertical with the working table. The user must not hold down the machine or attempt to prevent the machine from moving.

Do not get close to the machine and avoid touching the machine directly.

4. Put the cover in the start position, then rotate the loading arm until it locks.
5. Press the On/Off switch to “I”.
6. Do not mix on low speed at an extended period.
7. While the machine is in operation, extra food should be fed through the hole on the cover if needed.
8. Press the red stop button if the food cutting is finished. If the mixer is equipped with speed adjusting knob, then turn it to the “0” position and then stop the machine.

Maintenance

SHARPENING

Please sharpen the blades if the blades are not sharp enough to cut the food.

1. Turn off and unplug the machine.
2. Turn the loading arm to remove the cover.
3. Move the fixing axis of rotating blades away.
4. Use the sharpener from the manufacturer only. Sharpen the blade from the inside to outside along the blade edge.

CLEANING

- The machine should be cleaned at least once every day, more if necessary.

Maintenance

- The parts that touch the food directly or indirectly must be cleaned thoroughly.
- Water or high pressure spraying water cannot be used, as it will damage the machine. Brushes or other tools which may damage the surface also cannot be used.

The following procedures should be done before cleaning and maintenance:

- Turn off the power and unplug the unit.
- Turn the speed adjusting knob to the “0” position.

Clean the cover, rotating blades, axis and container

Rotate the loading arm, remove the cover, and the blade fixing axis and container can be lifted easily. Then use water and a neutral detergent to clean the above-mentioned parts.

Attention: Gloves should be worn for protection while operating and cleaning.

Attention: Machine must be switched off and unplugged.

Clean the machine body with a neutral detergent and damp cloth. Use a dry cloth to dry the machine after cleaning.

MAINTENANCE

BELT

The belt does not need to be adjusted.

FEET

As time goes on, the feet will deteriorate. You should change it to prevent accidents, please contact Omcan and request a replacement.

POWER CABLE

The power cable should be checked regularly. If it is damaged, please contact Omcan and request a replacement.

BLADES

Check whether the width of blades is less than 5cm. If it is, please contact Omcan and request a replacement.

LABEL

When the label is damaged, please contact Omcan and request a replacement.

Parts Breakdown

Model FP-CN-0006 23545

Model FP-CN-0009 23546

Model FP-CN-0012 47507

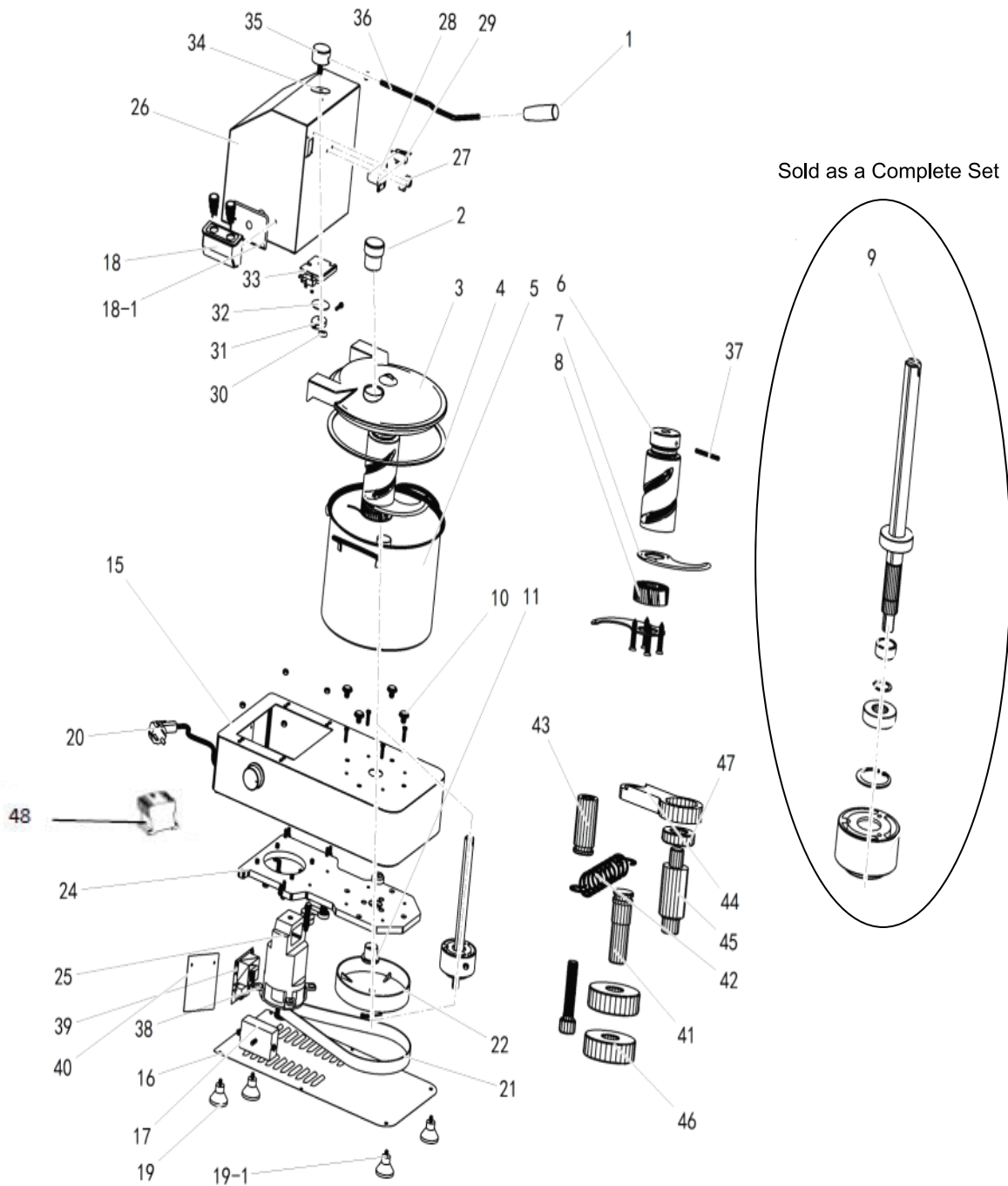

Parts Breakdown

Model FP-CN-0006 23545

Item No.	Description	Position	Item No.	Description	Position	Item No.	Description	Position
70288	Handle for 23545	1	70306	Rubber Feet for 23545	19	70324	Compression Bar for 23545	36
70289	Chuck Plug for 23545	2	70307	Power Cable for 23545	20	70325	Dowel for 23545	37
70290	PC Cover for 23545	3	70308	Belt for 23545	21	AK817	Motor Holder for 23545	38
70291	Water Proof Gasket for 23545	4	70309	Big Belt Pulley for 23545	22	AK818	Circuit Board for 23545	39
70292	Container for 23545	5	70312	Main Board for 23545	24	70328	Installation Board for 23545	40
70293	Up Tool Apron for 23545	6	AK816	Motor for 23545	25	70329	Tension Wheel Shaft for 23545	41
70294	Rotate Knives for 23545	7	70314	Welding for 23545	26	70330	Tension Spring for 23545	42
70295	Down Tool Apron for 23545	8	70315	Limited Block for 23545	27	70331	Small Shaft for 23545	43
70296	Complete Shaft Set for 23545	9	70316	Front Switch Holder for 23545	28	70332	Tension Wheel Arm for 23545	44
70297	Rubber Gasket for 23545	10	70317	Sure Model Switch for 23545	29	70333	Wheel Shaft 2 for 23545	45
71445	Locating Sleeve for 23545	11	70318	Big Nut for 23545	30	70334	Bearing 6200 for 23545	46
70301	Base Seat Component for 23545	15	70319	Cam for 23545	31	70335	Bearing 6800 for 23545	47
70302	Base Board for 23545	16	70320	Big Gasket for 23545	32	AI418	Contact for 23545	48
70303	Knob for 23545	17	70321	Up Switch Holder for 23545	33	AK755	Bowl Securing Latch for 23545	
70304	Switch Box Seal Bar for 23545	18	70322	Nylon Gasket for 23545	34			
70305	Gasket for Electric Box for 23545	18-1	70323	Handle Seat for 23545	35			

Parts Breakdown

Model FP-CN-0009 23546

Item No.	Description	Position	Item No.	Description	Position	Item No.	Description	Position
70336	Handle for 23546	1	70354	Rubber Feet for 23546	19	70372	Compression Bar for 23546	36
70337	Chuck Plug for 23546	2	70355	Power Cable for 23546	20	70373	Dowel for 23546	37
70338	PC Cover for 23546	3	70356	Belt for 23546	21	AK820	Motor Holder for 23546	38
70339	Water Proof Gasket for 23546	4	70357	Big Belt Pulley for 23546	22	AK821	Circuit Board for 23546	39
70340	Container for 23546	5	70360	Main Board for 23546	24	70376	Installation Board for 23546	40
70341	Up Tool Apron for 23546	6	AK819	Motor for 23546	25	70377	Tension Wheel Shaft for 23546	41
70342	Rotate Knives for 23546	7	70362	Welding for 23546	26	70378	Tension Spring for 23546	42
70343	Down Tool Apron for 23546	8	70363	Limited Block for 23546	27	70379	Small Shaft for 23546	43
78688	Complete Shaft Set for 23546	9	70364	Front Switch Holder for 23546	28	70380	Tension Wheel Arm for 23546	44
70345	Rubber Gasket for 23546	10	70365	Sure Model Switch for 23546	29	70381	Wheel Shaft 2 for 23546	45
41142	Locating Sleeve for 23546	11	70366	Big Nut for 23546	30	70382	Bearing 6200 for 23546	46
70349	Base Seat Component for 23546	15	70367	Cam for 23546	31	70383	Bearing 6800 for 23546	47
70350	Base Board for 23546	16	70368	Big Gasket for 23546	32	AI419	Contact for 23546	48
70351	Knob/Potentiometer for 23546	17	70369	Up Switch Holder for 23546	33	AK755	Bowl Securing Latch for 23546	
70352	Switch Box Seal Bar for 23546	18	70370	Nylon Gasket for 23546	34			
70353	Gasket for Electric Box for 23546	18-1	70371	Handle Seat for 23546	35			

Parts Breakdown

Model FP-CN-0012 47507

Item No.	Description	Position	Item No.	Description	Position	Item No.	Description	Position
AK822	Handle for 47507	1	AK838	Rubber Feet for 47507	19	AK854	Compression Bar for 47507	36
AK823	Chuck Plug for 47507	2	AK839	Power Cable for 47507	20	AK855	Dowel for 47507	37
AK824	PC Cover for 47507	3	AK840	Belt for 47507	21	AK856	Motor Holder for 47507	38
AK825	Water Proof Gasket for 47507	4	AK841	Big Belt Pulley for 47507	22	AK857	Circuit Board for 47507	39
AK826	Container for 47507	5	AK842	Main Board for 47507	24	AK858	Installation Board for 47507	40
AK827	Up Tool Apron for 47507	6	AK843	Motor for 47507	25	AK859	Tension Wheel Shaft for 47507	41
AK828	Rotate Knives for 47507	7	AK844	Welding for 47507	26	AK860	Tension Spring for 47507	42
AK829	Down Tool Apron for 47507	8	AK845	Limited Block for 47507	27	AK861	Small Shaft for 47507	43
AK830	Complete Shaft Set for 47507	9	AK846	Front Switch Holder for 47507	28	AK862	Tension Wheel Arm for 47507	44
AK831	Rubber Gasket for 47507	10	AK847	Sure Model Switch for 47507	29	AK863	Wheel Shaft 2 for 47507	45
AK832	Locating Sleeve for 47507	11	AK848	Big Nut for 47507	30	AK864	Bearing 6200 for 47507	46
AK833	Base Seat Component for 47507	15	AK849	Cam for 47507	31	AK865	Bearing 6800 for 47507	47
AK834	Base Board for 47507	16	AK850	Big Gasket for 47507	32	AK866	Contact for 47507	48
AK835	Knob for 47507	17	AK851	Up Switch Holder for 47507	33	AK755	Bowl Securing Latch for 47507	
AK836	Switch Box Seal Bar for 47507	18	AK852	Nylon Gasket for 47507	34			
AK837	Gasket for Electric Box for 47507	18-1	AK853	Handle Seat for 47507	35			

Electrical Schematics

Model FP-CN-0006 23545

Model FP-CN-0009 23546

Model FP-CN-0012 47507

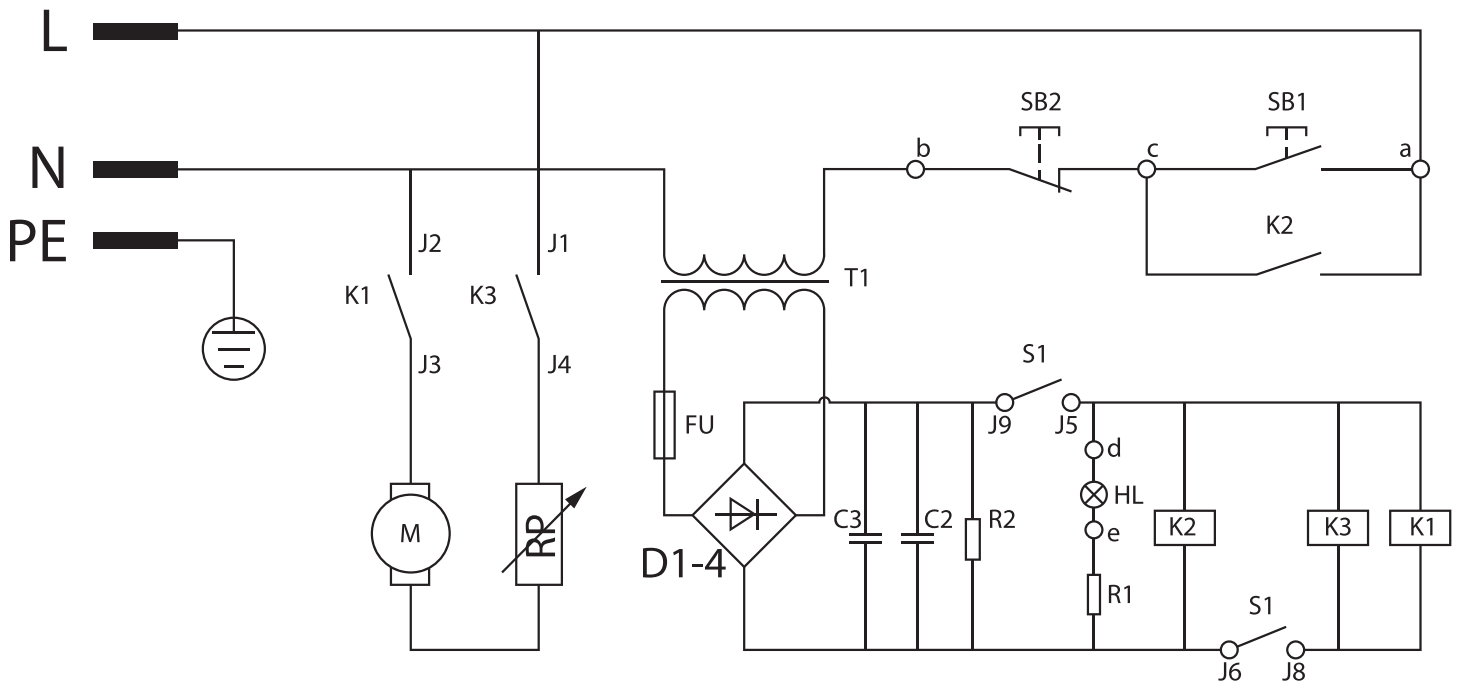

Position	Description	Position	Description	Position	Description
C2 - C3	Capacitor	K1 - K3	Relay	S1 - S2	Location of Switch
D1-4	Rectifier Bridge	M	Motor	SB1	Start Button
FU	Fuse	R1 - R2	Resistance	SB2	Stop Button
HL	Indicator Light	RP	Speed Regulator	T1	Transformer



Warranty Registration

Thank you for purchasing an Omcan product. To register your warranty for this product, complete the information below, tear off the card at the perforation and then send to the address specified below. You can also register online by visiting:

Merci d'avoir acheté un produit Omcan. Pour enregistrer votre garantie pour ce produit, complétez les informations ci-dessous, détachez la carte au niveau de la perforation, puis l'envoyer à l'adresse spécifiée ci-dessous. Vous pouvez également vous inscrire en ligne en visitant:

Gracias por comprar un producto Omcan usted. Para registrar su garantía para este producto, complete la información a continuación, cortar la tarjeta en la perforación y luego enviarlo a la dirección indicada a continuación. También puede registrarse en línea en:

<https://omcan.com/warranty-registration/>

For mailing in Canada

Pour postale au Canada

Por correo en Canadá

OMCAN

PRODUCT WARRANTY REGISTRATION

3115 Pepper Mill Court,

Mississauga, Ontario

Canada, L5L 4X5

For mailing in the US

Pour diffusion aux États-Unis

Por correo en los EE.UU.

OMCAN

PRODUCT WARRANTY REGISTRATION

4450 Witmer Industrial Estates, Unit 4,

Niagara Falls, New York

USA, 14305

or email to: service@omcan.com



Purchaser's Information

Name: _____

Address: _____

City: _____ Province or State: _____ Postal or Zip: _____

Country: _____

Dealer from which Purchased: _____

Dealer City: _____ Dealer Province or State: _____

Invoice: _____

Model Name: _____ Model Number: _____

Machine Description: _____

Date of Purchase (MM/DD/YYYY): _____

Would you like to extend the warranty? Yes No

Company Name: _____

Telephone: _____

Email Address: _____

Type of Company:

Restaurant Bakery Deli

Butcher Supermarket Caterer

Institution (*specify*): _____

Other (*specify*): _____

Serial Number: _____

Date of Installation (MM/DD/YYYY): _____

Thank you for choosing Omcan | Merci d'avoir choisi Omcan | Gracias por elegir Omcan



Since 1951 Omcan has grown to become a leading distributor of equipment and supplies to the North American food service industry. Our success over these many years can be attributed to our commitment to strengthen and develop new and existing relationships with our valued customers and manufacturers. Today with partners in North America, Europe, Asia and South America, we continually work to improve and grow the company. We strive to offer customers exceptional value through our qualified local sales and service representatives who provide convenient access to over 6,500 globally sourced products.

Depuis 1951 Omcan a grandi pour devenir un des “leaders” de la distribution des équipements et matériel pour l’industrie des services alimentaires en Amérique du Nord. Notre succès au cours de ces nombreuses années peut être attribué à notre engagement à renforcer et à développer de nouvelles et existantes relations avec nos clients et les fabricants de valeur. Aujourd’hui avec des partenaires en Amérique du Nord, Europe, Asie et Amérique du Sud, nous travaillons continuellement à améliorer et développer l’entreprise. Nous nous efforçons d’offrir à nos clients une valeur exceptionnelle grâce à nos ventes locales qualifiées et des représentants de service qui offrent un accès facile à plus de 6500 produits provenant du monde entier.

Desde 1951 Omcan ha crecido hasta convertirse en un líder en la distribución de equipos y suministros de alimentos en América del Norte industria de servicios. Nuestro éxito en estos años se puede atribuir a nuestro compromiso de fortalecer y desarrollar nuevas relaciones existentes con nuestros valiosos clientes y fabricantes. Hoy con socios de América del Norte, Europa, Asia y América del Sur, que trabajan continuamente para mejorar y crecer la empresa. Nos esforzamos por ofrecer a nuestros clientes valor excepcional a través de nuestro local de ventas y representantes de los servicios que proporcionan un fácil acceso a más de 6,500 productos con origen a nivel mundial.

